

# Trina smart DC

## THE OPTIMIZED SOLUTION

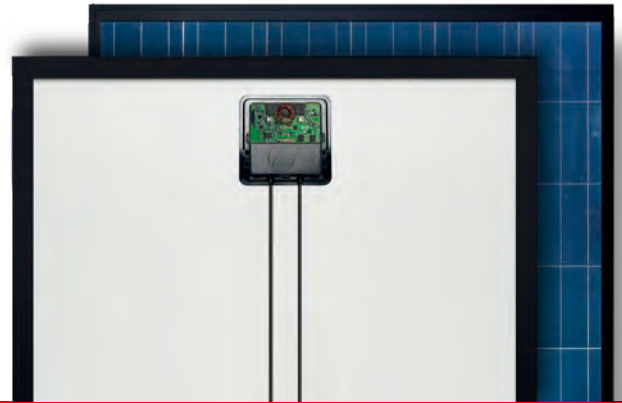

**250-260 W**  
POWER OUTPUT RANGE

**FULLY INTEGRATED**  
SMART SOLUTION

As a leading global manufacturer of next generation photovoltaic products, we believe close cooperation with our partners is critical to success. With local presence around the globe, Trina is able to provide exceptional service to each customer in each market and supplement our innovative, reliable products with the backing of Trina as a strong, bankable partner. We are committed to building strategic, mutually beneficial collaboration with installers, developers, distributors and other partners as the backbone of our shared success in driving Smart Energy Together.

Trina Solar Limited  
[www.trinasolar.com](http://www.trinasolar.com)

**Trinasolar**  
Smart Energy Together



### Safer Solar

- Panel-level disconnect to remotely deactivate modules
- Arc, fire and safety hazard mitigation



### More Efficient O&M

- Panel-level monitoring to pinpoint problems
- Detailed real-time alerts and analytics



### Highest Power Density

- Install more modules on any roof
- Uneven string lengths enables design flexibility



### Maximized Energy Harvest

- Impedance matching technology eliminates mismatch losses
- More power from each module bin



### Lower BOS Costs from Smart Curve Technology

- 30% lower max open circuit voltage, 30% longer strings
- Fewer combiners, fuses and copper wiring required



### Fully Integrated

- Compatible with any inverter
- No additional boxes to mount on module

## LINEAR PERFORMANCE WARRANTY

10 Year Product Warranty • 25 Year Linear Power Warranty

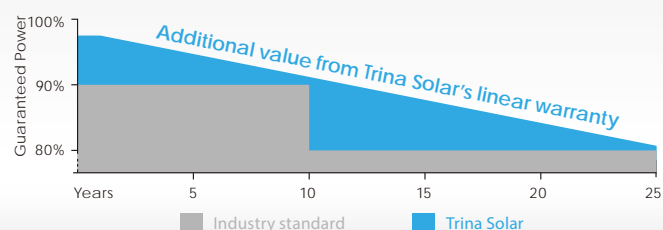

# Trinasmart DC

Trinasmart modules incorporate innovative power electronics from Tigo Energy to achieve module-level diagnostics, maximum energy harvest through module level DC power optimization, and reduction of arc, fire and safety hazards.

Integration of the module optimizer into the junction-box enables patented Smart Curve technology, which allows up to 30% longer strings and significant balance-of-system (BOS) savings.

## SYSTEM ARCHITECTURE

Trinasmart system components work together with any inverter to maximize energy harvest. Trinasmart modules communicate wirelessly through the gateway, allowing users to monitor system performance in real time.

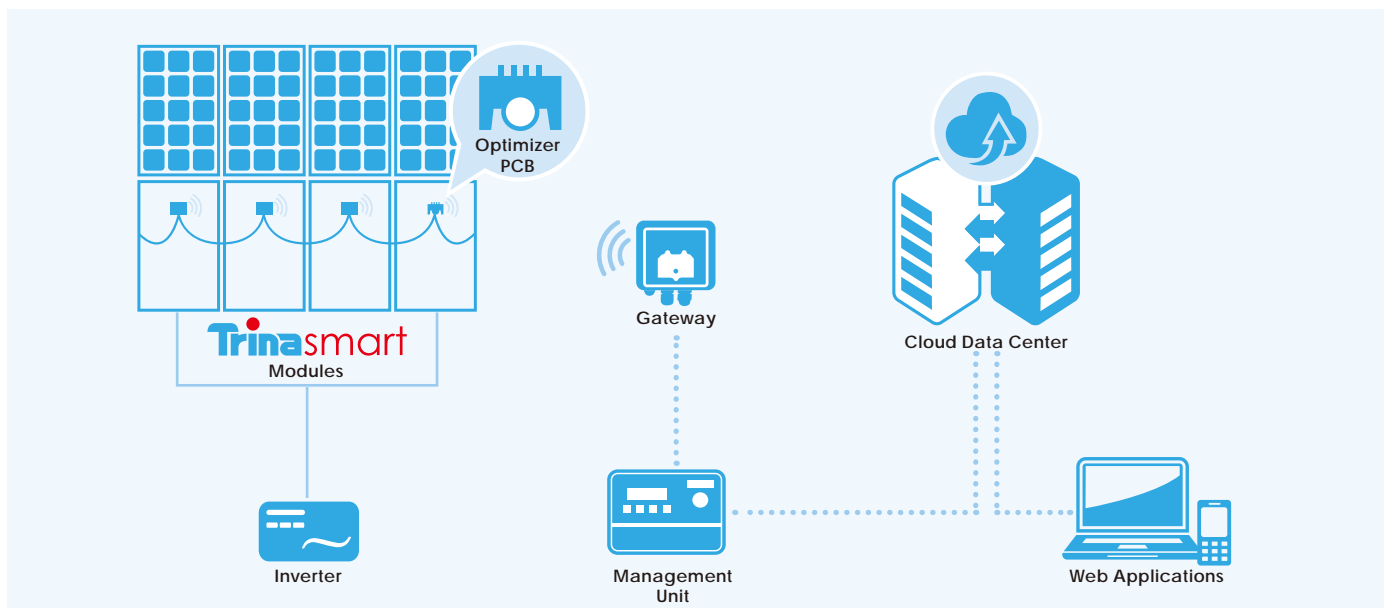

## SMART CURVE TECHNOLOGY

Module-integrated Trinasmart technology reduces the open circuit voltage range for each module and allows longer strings to be designed. The maximum voltage is programmed by Trina Solar in the factory.

- Hardware voltage clamp prevents over-voltage
- Design up to 30% longer strings
- Fewer combiner boxes, fuses and wiring
- Smaller resistance losses
- TUV & CSA certified

■ With Smart-Curve      ■ Without Smart-Curve

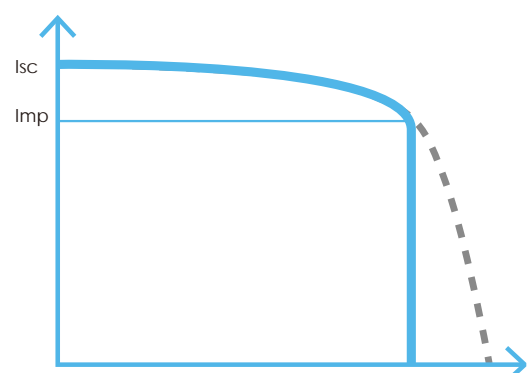

## MODULE MANAGEMENT UNIT (MMU)

The management unit controls processes in real time and sends data to a remote server for monitoring.

SPECIFICATIONS ONE UNIT SUPPORTS UP TO 360 TRINASMART MODULES		
Communication	Data Backhaul	Ethernet (MMU to Data Center)
	On-Screen Prompts	Module (power, voltage, signal), Internet Check, basic troubleshooting
	PV-Safe	Button deactivates the array (at the module-level)
	Accessories	Pull data from most meters that speak Modbus (i.e. AC Meters)
	Inverter Data	Can pull data from most inverters (SMA, Power One, Fronius, Kaco)
Power	Compatibility	110 / 230V compatible converter (comes with international plugs)
Mechanical Specifications	Dimensions (L x W x H)	225.5x 226 x125 mm
	Weight	1 kg
	Environmental Rating	NEMA 3R
	Operating Temperature	0° to +70° C



Module Management Unit (MMU)

## GATEWAY

The Gateway provides wireless communication with up to 120 Trinasmart modules and the MMU. Up to seven Gateways can be connected to a single MMU.

GATEWAY SPECIFICATIONS		
MMU Communications	Wireless (802.15)	
	RS-485 cable connection; in series with other Gateways	
Mounting Location	Center of array	
Mounting Method	Mounted to module frame or rack Clips included for frame mounting	
Wireless Range	15m line-of-sight	
Maximum number of Trinasmart modules per Gateway	120	
Mechanical Specifications	Dimensions	141.3 x 48.5 x 33.3 mm (with bracket)
	Weight	0.9kg
	Operating temperature range	-30° C +70° C
	Enclosure environmental rating	IP 65



Gateway

**An internet connection and a gateway are required for full system functionality.** The wireless communications system is FCC and CE Class 2 certified. Fixing hole comes with a M3.5X6 SST pan head screw.

## MONITORING SERVICE

Trinasmart monitoring provides total insight into the performance of any system. You can choose to upgrade online once your system is installed.



Explore the monitoring portal at [www.trinasmart.com](http://www.trinasmart.com)

FEATURES	FREE	PREMIUM*
Reports	Monthly	Daily
1-min Data Granularity	30-days	Full History
Full History	•	•
Safety Alerts	•	•
Dashboard Showing Environmental Impact	•	•
Performance Analytics		•
Trending Data Charts		•
Download Ability		•
Device Integration		•
Performance Alerts		•
API Access		•

\* Premium service provided by Tigo Energy

# Trinasmart DC THE OPTIMIZED SOLUTION TSM-PC05A.082

## DIMENSIONS OF PV MODULE

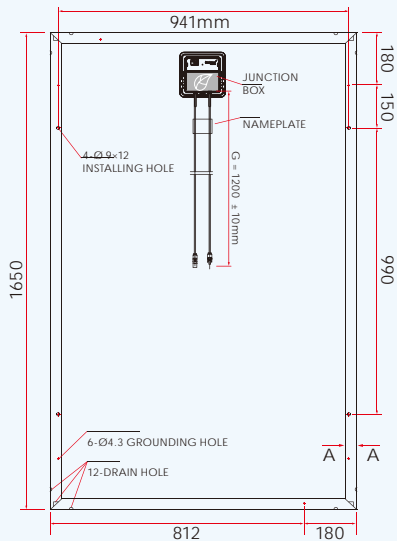

Back View

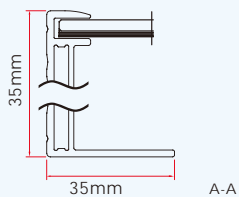

## I-V CURVES OF PV MODULE (255W)

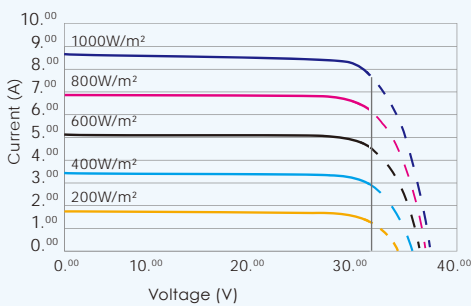

## CERTIFICATION



## ELECTRICAL DATA (STC)

Peak Power Watts- $P_{MAX}$ (Wp)	250	255	260
Power Output Tolerance- $P_{MAX}$ (%)	0 ~ +3		
Maximum Power Voltage- $V_{MPP}$ (V)	30.3	30.5	30.6
Maximum Power Current- $I_{MPP}$ (A)	8.27	8.37	8.50
Open Circuit Voltage- $V_{oc}^*$ (V)	33.4	33.4	33.4
Short Circuit Current- $I_{sc}$ (A)	9.50	9.50	9.50
Module Efficiency $\eta_m$ (%)	15.3	15.6	15.9

Average power delivered by modules is guaranteed to be greater than Peak Power Watts  
 STC: Irradiance 1000W/m<sup>2</sup>, Cell Temperature 25°C, Air Mass AM1.5 according to EN 60904-3  
 Typical efficiency reduction of 4.5% at 200 W/m<sup>2</sup> according to EN 60904-1  
 \* Trinasmart modules limit the open circuit voltage

## ELECTRICAL DATA (NOCT)

Maximum Power- $P_{MAX}$ (Wp)	179	183	186	190
Maximum Power Voltage- $V_{MPP}$ (V)	26.9	27.3	27.4	27.5
Maximum Power Current- $I_{MPP}$ (A)	6.66	6.70	6.79	6.91
Open Circuit Voltage- $V_{oc}^*$ (V)	33.4	33.4	33.4	33.4
Short Circuit Current- $I_{sc}$ (A)	9.50	9.50	9.50	9.50

NOCT: Irradiance at 800 W/m<sup>2</sup>, Ambient Temperature 20°C, Wind Speed 1 m/s.

## MECHANICAL DATA

Solar Cells	Multicrystalline 156 × 156mm (6 inches)
Cell Orientation	60 cells (6 × 10)
Module Dimension	1650 x 992 x 35mm
Weight	19 kg
Glass	High Transmission, Low Iron, Tempered Glass, 3.2mm
Backsheet	White
Frame	Black Anodized Aluminium Alloy
J-Box	IP 65 rated
Cables / Connector	Photovoltaic Technology cable 4.0mm <sup>2</sup> (0.006 inches <sup>2</sup> ), 1200 mm (47.2 inches); H4/MC4

## TEMPERATURE RATINGS

Nominal Operating Cell Temperature (NOCT)	44°C (±2°C)
Temperature Coefficient of $P_{MAX}$	- 0.41%/°C
Temperature Coefficient of $V_{oc}$	0%/°C
Temperature Coefficient of $I_{sc}$	0.05%/°C

## MAXIMUM RATINGS

Operational Temperature	-40 ~ +85°C
Maximum System Voltage	1000V DC (IEC)
Max Series Fuse Rating	15A

## WARRANTY

- 10 year workmanship warranty
- 25 year linear performance warranty

(Please refer to product warranty for details)

## PACKAGING CONFIGURATION

- Modules per box: 29 pcs
- Modules per 40' container: 812 pcs

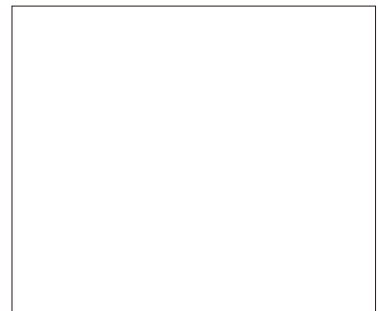

TSM\_EN\_Jan\_2014\_B